

INSTRUCTION MANUAL

Meat Grinders

Item	11051	11053	39714
Model	MG-IT-0012-C	MG-IT-0022-C	MG-IT-0032-C



Warning!

Before you begin using your appliance, **PLEASE READ AND UNDERSTAND THIS DOCUMENT CAREFULLY** before installing, operating, maintaining, or servicing.

There are many important safety messages in this manual and on your appliance. Always read all safety messages.

Failure to do so can result in appliance failure, property damage, serious injury or death. Appliance failure, injury or property damage due to improper installation is not covered by warranty.

Stop!

DO NOT RETURN THIS PRODUCT TO THE STORE!

For questions or assistance with this product, call TRENTO Toll free: **1-833-487-3686** or visit the support section from our website, **www.trentoequipment.com**

Version: Revised - 08/02/2024



TABLE OF CONTENTS

Section	Page
General Information -----	3 - 4
Safety and Warranty -----	4 - 5
Technical Specifications -----	6
Installation and Operation -----	6 - 8
Maintenance -----	8 - 9
Troubleshooting -----	9 - 10
Parts Breakdown -----	11 - 16
Electrical Schematics -----	17 - 19
Notes -----	20 - 22
Warranty Registration -----	23

GENERAL INFORMATION

Omcan Manufacturing and Distributing Company Inc., Food Machinery of America, Inc. dba Omcan and Omcan Inc. are not responsible for any harm or injury caused due to any person's improper or negligent use of this equipment. The product shall only be operated by someone over the age of 18, of sound mind, and not under the influence of any drugs or alcohol, who has been trained in the correct operation of this machine, and is wearing authorized, proper safety clothing. Any modification to the machine voids any warranty, and may cause harm to individuals using the machine or in the vicinity of the machine while in operation.

CHECK PACKAGE UPON ARRIVAL

Upon receipt of an Omcan shipment please inspect for external damage. If no damage is evident on the external packaging, open carton to ensure all ordered items are within the box, and there is no concealed damage to the machine. If the package has suffered rough handling, bumps or damage (visible or concealed), please note it on the bill of lading before accepting the delivery and contact Omcan within 24 hours, so we may initiate a claim with the carrier. A detailed report on the extent of the damage caused to the machine must be filled out within three days, from the delivery date shown in the shipping documents. Omcan has no recourse for damaged products that were shipped collect or third party.

Before operating any equipment, always read and familiarize yourself with all operation and safety instructions.

Omcan would like to thank you for purchasing this machine. It's of the utmost importance to save these instructions for future reference. Also save the original box and packaging for shipping the equipment if servicing or returning of the machine is required.

Omcan Fabrication et distribution Compañie Limité et Food Machinery d'Amérique, dba Omcan et Omcan Inc. ne sont pas responsables de tout dommage ou blessure causé du fait que toute personne ait utilisé cet équipement de façon irrégulière. Le produit ne doit être exploité que par quelqu'un de plus de 18 ans, saine d'esprit, et pas sous l'influence d'une drogue ou d'alcool, qui a été formé pour utiliser cette machine correctement, et est vêtu de vêtements de sécurité approprié. Toute modification de la machine annule toute garantie, et peut causer un préjudice à des personnes utilisant la machine ou des personnes à proximité de la machine pendant son fonctionnement.

VÉRIFIEZ LE COLIS DÈS RÉCEPTION

Dès réception d'une expédition d'Omcan veuillez inspecter pour dommages externes. Si aucun dommage n'est visible sur l'emballage externe, ouvrez le carton afin de s'assurer que tous les éléments commandés sont dans la boîte, et il n'y a aucun dommage dissimulé à la machine. Si le colis n'a subi aucune mauvaises manipulations, de bosses ou de dommages (visible ou cachée), notez-le sur le bond de livraison avant d'accepter la livraison et contactez Omcan dans les 24 heures qui suivent, pour que nous puissions engager une réclamation auprès du transporteur. Un rapport détaillé sur l'étendue des dommages causés à la machine doit être rempli dans un délai de trois jours, à compter de la date de livraison indiquée dans les documents d'expédition. Omcan n'a aucun droit de recours pour les produits endommagés qui ont été expédiées ou cueilli par un tiers transporteur.

Avant d'utiliser n'importe quel équipement, toujours lire et vous familiariser avec toutes les opérations et les

GENERAL INFORMATION

consignes de sécurité.

Omcan voudrais vous remercier d'avoir choisi cette machine. Il est primordial de conserver ces instructions pour une référence ultérieure. Également conservez la boîte originale et l'emballage pour l'expédition de l'équipement si l'entretien ou le retour de la machine est nécessaire.

Omcan Empresa De Fabricacion Y Distribucion Inc. Y Maquinaria De Alimentos De America, Inc. dba Omcan y Omcan Inc. no son responsables de ningun daño o perjuicio causado por cualquier persona inadecuada o el uso descuidado de este equipo. El producto solo podra ser operado por una persona mayor de 18 años, en su sano juicio y no bajo alguna influencia de droga o alcohol, y que este ha sido entrenado en el correcto funcionamiento de esta máquina, y ésta usando ropa apropiada y autorizada. Cualquier modificación a la máquina anula la garantía y puede causar daños a las personas usando la máquina mientras esta en el funcionamiento.

REVISE EL PAQUETE A SU LLEGADA

Tras la recepcion de un envio Omcan favor inspeccionar daños externos. Si no hay daños evidentes en el empaque exterior, Habra el carton para asegurarse que todos los articulos solicitados estén dentro de la caja y no encuentre daños ocultos en la máquina. Si el paquete ha sufrido un manejo de poco cuidado, golpes o daños (visible o oculto) por favor anote en la factura antes de aceptar la entrega y contacte Omcan dentro de las 24 horas, de modo que podamos iniciar una reclamación con la compañía. Un informe detallado sobre los daños causados a la máquina debe ser llenado en el plazo de tres días, desde la fecha de entrega que se muestra en los documentos de envío. Omcan no tiene ningun recurso por productos dañados que se enviaron a recoger por terceros.

Antes de utilizar cualquier equipo, siempre lea y familiarizarse con todas las instrucciones de funcionamiento y seguridad.

Omcan le gustaría darle las gracias por la compra de esta máquina. Es de la mayor importancia para salvar estas instrucciones para futuras consultas. Además, guarda la caja original y el embalaje para el envío del equipo si servicio técnico o devolución de la máquina que se requiere.

SAFETY AND WARRANTY

WARNINGS ON THE RESIDUAL RISKS

RESIDUAL RISK DUE TO THE FIXED PROTECTIONS REMOVAL OR INTERRUPTION ON BROKEN/WORN PARTS.

The operator must not try to open or remove a fixed protection or tamper with a safety device.

During operation, maintenance and cleaning, keep hands or other body parts away from the machines

SAFETY AND WARRANTY

dangerous areas, a residual risk remains due to:

1. Knocks with the machines manufacturing parts.
2. Grazing and/or abrasion with the machines rough parts.
3. Cuts with the sharp parts.

PROTECTION DEVICES ON THE MACHINE

The machine protections and safety devices must not be removed, never operate without attaching the hopper.

The machines transmission parts are completely isolated by means of fixed protections which does not allow access. The moving elements are not isolated from fixed protections, moving protections or other safety devices. The grinding group parts are placed away from access points so they are not reachable.

DISCLAIMER

PLEASE RUN THE UNIT WITH A LIGHT, DISPOSABLE LOAD TO REMOVE ANY METAL SHAVINGS FROM THE MACHINE BEFORE FIRST USE!

RESIDENTIAL USERS: vendor assumes no liability for parts or labor coverage for component failure or other damages resulting from installation in non-commercial or residential applications. The right is reserved to deny shipment for residential usage; if this occurs, you will be notified as soon as possible.

1 YEAR PARTS AND LABOUR BENCH WARRANTY

Within the warranty period, contact Omcan Inc. at 1-800-465-0234 to schedule a drop off to either an Omcan authorized service depot in the area, or to an Omcan Service warehouse to repair the equipment.

Unauthorized maintenance will void the warranty. Warranty covers electrical and part failures, not improper use.

Please see <https://omcan.com/disclaimer> for complete info.

WARNING:

The packaging components are classified as normal solid urban waste and can therefore be disposed of without difficulty.

In any case, for suitable recycling, we suggest disposing of the products separately (differentiated waste) according to the current norms.

DO NOT DISCARD ANY PACKAGING MATERIALS IN THE ENVIRONMENT!

TECHNICAL SPECIFICATIONS

Item Number	11051	11053	39714
Model	MG-IT-0012-C	MG-IT-0022-C	MG-IT-0032-C
Throat Opening	2" / 51mm		2.7" / 69mm
Power	1 HP / 750 W	1.5 HP / 1120 W	3 HP / 2200 W
Electrical	110-120V / 60Hz / 1		220V / 60Hz / 1
Net Weight	41.9 lbs. / 19 kgs.	50 lbs. / 22.7 kgs.	114.6 lbs. / 52 kgs.
Net Dimensions (WDH)	8" x 16.2" x 17.5" 203 x 412 x 444mm	9" x 17" x 20" 229 x 432 x 508mm	11.8" x 22.5" x 22" 300 x 571 x 560mm
Packaging Weight	43.2 lbs. / 19.6 kgs.	54.7 lbs. / 24.8 kgs.	121.3 lbs. / 55 kgs.
Packaging Dimensions	9.5" x 17.5" x 17.5" 241 x 444 x 444mm	19.5" x 12" x 20.5" 495 x 305 x 521mm	16.9" x 24.4" x 25.6" 430 x 620 x 650mm

INSTALLATION AND OPERATION

TRANSPORTATION, HANDLING AND STORAGE

All transportation and handling operations must be performed from trained personnel and must have read and understood the safety precautions mentioned in this manual.

1. Perform the machine handling and transportation only when unplugged.
2. Verify that the lifting means are able to support the loading weight and overall dimensions in safe conditions.
3. Avoid dropping or shaking the unit during transportation.

PREPARATION PRELIMINARY OPERATIONS

STABILITY

The machines stability is designed so that it can be used without the risk of falling or unwanted movement.

ELECTRICAL SUPPLY

The electrical supply connection must be in conformance with the country legislation in which it is being used.

1. The electrical supply must match the required specifications indicated on the rating plate. If excessive voltages are applied, some components will be damaged beyond repair.
2. The device must be grounded in conformance to the local standards.
3. The electrical supply cable outside the machine cover must be adequately protected.

GRINDING GROUP ASSEMBLY / DISASSEMBLY

The assembly / disassembly operations of any machine part are performed with the machine in the OFF

INSTALLATION AND OPERATION

position, and the plug disconnected from the socket.

To assemble the grinder, do the following steps in this order:

1. Insert into the shaft (1) in order: the worm (2), the cutting knife oriented as shown in the figure (3), and the plate (4).
2. Screw down and tighten the screw (5).

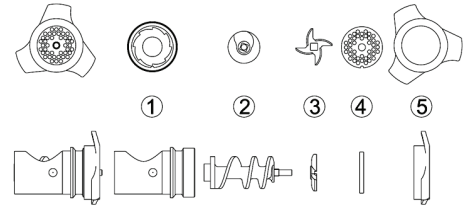

To disassemble, do the above in reverse order.

FUNCTIONING DESCRIPTION

STARTING THE MACHINE

To start the machine, the switch has to be placed on the "I" position.

STOPPING THE MACHINE

To stop the machine, the switch has to be placed on the "O" position.

FUNCTIONING SAFETY

If the machine is under stress, operated for a long period of time or overloaded, stop immediately for the thermal protection functioning. In this case wait for the unit to cool completely before using again.

OPERATION

The machine operator can begin operation of the machine when:

1. The machine is installed properly.
2. The machine is connected to the electrical supply.
3. The hopper is inserted in the correct position.
4. The grinding group assembly is installed correctly.
5. The worm rotates in the correct direction.
6. Tests the switch.
7. Checks that all safety conditions are being met.
8. Checks that the plug is in the correct socket.
9. Place a collecting tray below the shaft to collect the final product.
10. Start the machine by placing the switch to the "I" position.
11. Manually introduce the chopped meat into the machine neck and use the supplied stomper to push the meat into the shaft.
12. Once the operation is completed, or when the product no longer comes out of the plate, place the switch to the "O" position to stop the machine.

It is recommended to only operate the machine when there is product in the unit.

Note: Item 39714 can run in reverse, but the button must be held down when doing so.

AFTER EACH USE

Once the machine has been operated and is no longer needed for use, please do the following:

INSTALLATION AND OPERATION

1. Before turning off the unit, wait until the food product has finished going through the plate.
2. Turn off the machine by placing the switch to the "O" position.
3. Unplug the unit from the electrical socket.
4. Perform the cleaning and maintenance steps detailed in the "maintenance" section.

UNBLOCK IN CASE OF OBSTRUCTION

During operation, or during the worm rotation, due to the food products being introduced with incompatible parts (ie: bones), the machine could become blocked and cause a malfunction.

To be able to resume normal operation, the grinding group must be disassembled, and the blockage must be removed.

MAINTENANCE

PROTECTIVE SAFETY DEVICES

For any procedures described in this section, it is necessary to remove some of the fixed protections from their positions. The removal can only be performed by an authorized Omcan technician. At the end of the maintenance procedures, these protections must be replaced and fastened in their original positions.

The machine must be switched off and unplugged prior to any maintenance and cleaning.

EXTRAORDINARY MAINTENANCE

In the event of any extraordinary maintenance, it can only be completed by an authorized Omcan service technician.

OIL REPLACEMENT

Oil does not need to be replaced during normal operation. Oil should be filled up to 80% only after servicing. It can only be completed by an authorized Omcan service technician.

CLEANING

All cleaning procedures must be started only when the machine is no longer in operation and is unplugged from the electrical socket.

The machine, the electrical equipment and electrical components must never be submerged, sprayed, or washed with water. Use a dry cloth to wipe these components.

MAINTENANCE

Follow the steps as listed:

FREQUENCY	PERSONNEL	CATEGORY	SOLUTIONS
At the end of every use and before daily use.	Operator	DISINFECTION	Use PH neutral detergents.
			Use demineralized water if temperatures exceed 60°C/140°F.
			If any other products are used, they must be adequate to the materials being disinfected.
		PERIODS OF LONG INACTIVITY	If the machine has been inactive for a long period of time, vigorously wipe the machine with a cloth soaked in Vaseline to create a protective barrier.
		PRODUCTS NOT TO USE	Compressed or pressurized air jets.
			Vapor equipment.
			Detergent that contains any of the following compounds: - Bleach. - Hydrochloric acid. - Products that are used to clear drains. - Caustic soda products for cleaning marble. - Etc.
			Steel wool, brushes or abrasive discs produced with other metals or alloys, or tools that have previously cleaned other metals or alloys.
			Detergents in abrasive dust.
			Fuel, solvents or inflammable and/or corrosive fluids.
Substances used to clean silver.			

TROUBLESHOOTING

The following indicated problems that may occur:

TYPE	POTENTIAL CAUSES	SOLUTIONS
The electrical supply is not adequate.	General blackout.	Contact an electrician.
	Blown fuse.	Replace the fuse, if the problem continues, contact an electrician.

TROUBLESHOOTING

The machine stops.	The protection device stops the machine.	Contact an electrician to eliminate the causes, once the cause has been determined, restore the machine to the recommended function.
	The cause could not be identified.	Contact Omcan directly.
The machine doesn't function: the worm will not rotate.	The electrical supply is not adequate.	Check and restore the electrical supply.
	The switch is on the "O" position.	Place the switch to the "I" position.
	Blown fuse.	Replace the fuse.
	The unit is overheated.	Wait for the unit to cool completely before starting.

PARTS BREAKDOWN

ITEM	MODEL
11051	MG-IT-0012-C

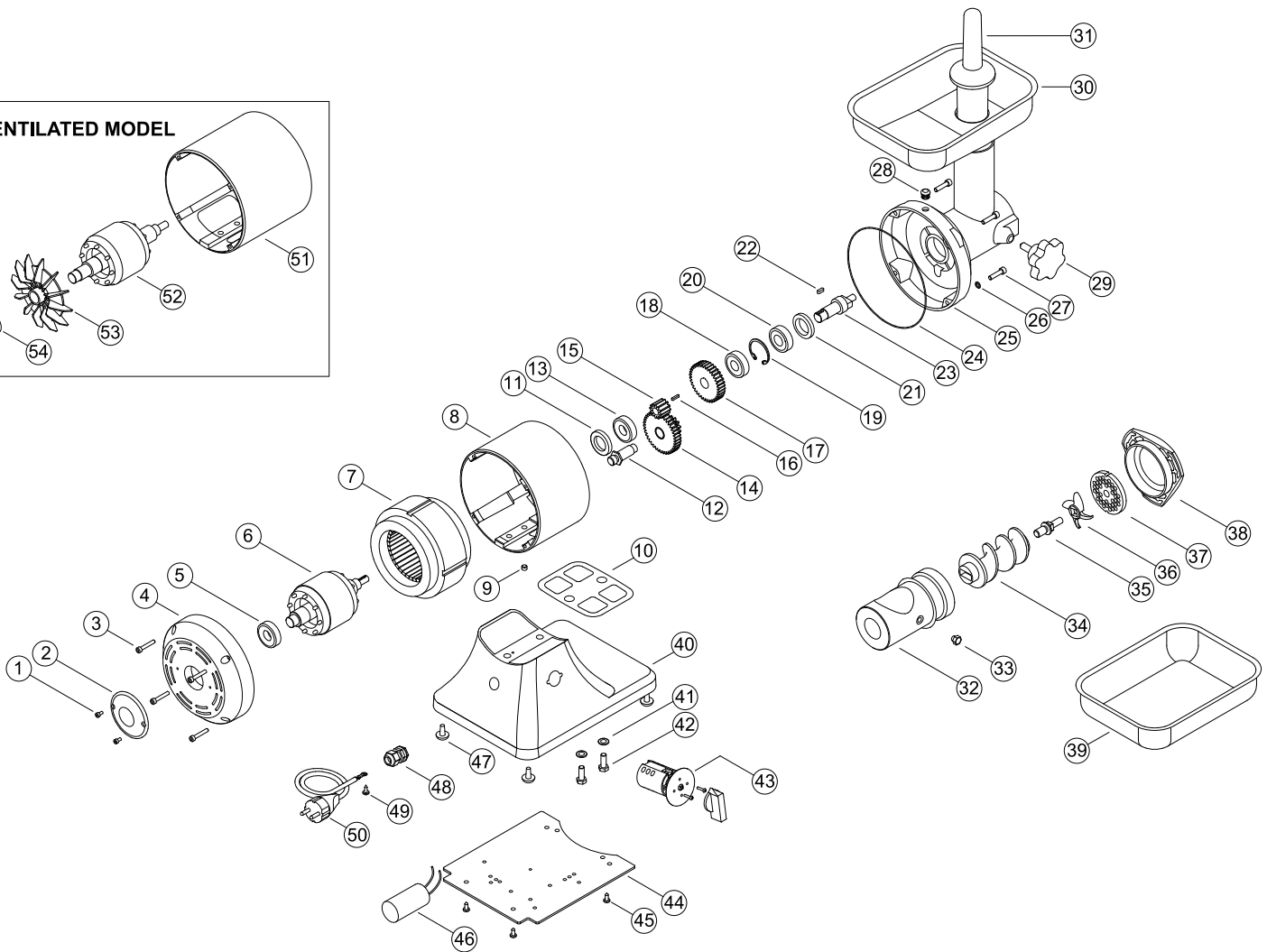
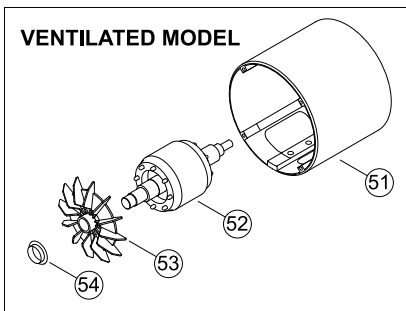

PARTS BREAKDOWN

ITEM	MODEL
11051	MG-IT-0012-C

Item No.	Description	Position	Item No.	Description	Position	Item No.	Description	Position
15351	Screw 4x8 for 11051	1	15394	Seeger of 40 for 11051	19	15406	Aluminum Ring for 11051	38
15352	Disc Locking ABS DA 80mm for 11051	2	15389	Bearing 6203 2RS for 11051	20	15362	Pan for 11051	39
68910	Aluminum Closing Disc 80mm for 11051	2	15387	Oil Seal 40x25x7 for 11051	21	15408	Base for 11051	40
15353	Screw 5x30 for 11051	3	46421	Key 4x4x12mm for Big Gear for 11051	22	70181	Washer 8x16x1.5 (4 pcs.) for 11051	41
15380	Back Motor Cover for 11051	4	15395	Transmission Pin for 11051	23	15410	Screw 8x22 for 11051	42
15381	Bearing 6203 ZZ for 11051	5	15458	Ring 164 5x2 - Oil Seal for 11051	24	17701	Switch for 11051	43
15383	Rotor V.110/60 for 11051	6	15396	Jacket Holder for 11051	25	19378	Bipolar Switch for 11051	43
15468	Stator 110V/60Hz for 11051	7	15459	Washer for 11051	26	15411	Rubber Base Cover for 11051	44
AI208	Short Banded Motor Housing for 11051	8	15397	Screw 6x25 for 11051	27	15412	Screw 4 8x12 for 11051	45
AD423	Wheat 8x6 for 11051	9	15398	Plug for Oil Opening (Rubber) for 11051	28	15413	Capacitor for 11051	46
15460	Base Guard for 11051	10	15401	Knob for 11051	29	42904	Rubber Foot for 11051	47
15387	Oil Seal 40x25x7 for 11051	11	15399	Hopper for 11051	30	15407	Grand PG11 for 11051	48
15447	Gear Pin for 11051	12	15400	Plunger for 11051	31	15351	Screw 4x8 for 11051	49
15389	Bearing 6203 2RS for 11051	13	79600	Steel Grinding Head for 11051	32	70168	Cable with Plug Mod.Schuko V.230 for 11051	50
15392	Double Gear for 11051	14	15402	Grub Screw for 11051	33	AI209	Long Banded Motor Housing for 11051	51
15390	Propeller Gear for 11051	15	49488	Stainless Steel Worm and Pin for 11051	34	AI210	Shaft with Rotor V.230 / 50 Hz. Ventilated for 11051	52
15391	Key 3x3x15mm for 11051	16	17235	Worm Pin Stainless Steel for 11051	35	15415	Fan for 11051	53
15393	Gear for 11051	17	Call for Options	Blade for 11051	36	15414	Ring for 11051	54
15381	Bearing 6203 ZZ for 11051	18	Call for Options	Plate for 11051	37			

PARTS BREAKDOWN

ITEM	MODEL
11053	MG-IT-0022-C

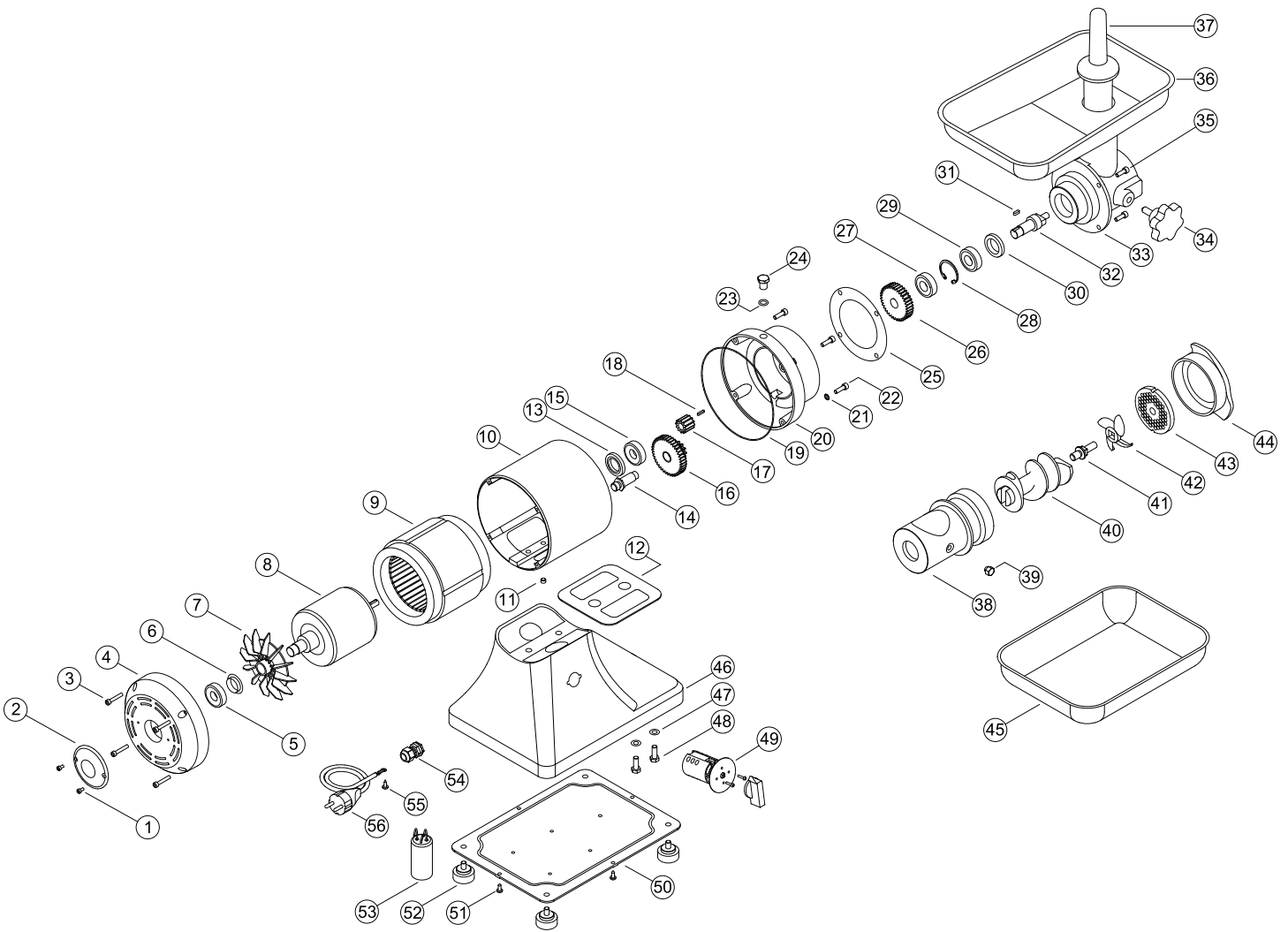

PARTS BREAKDOWN

ITEM	MODEL
11053	MG-IT-0022-C

Item No.	Description	Position	Item No.	Description	Position	Item No.	Description	Position
15351	Screw 4x8 for 11053	1	15441	Motor Cover - Front for 11053	20	15453	Worm and Pin Aluminum for 11053	40
15352	Disc Locking ABS DA 80mm for 11053	2	15459	Washer for 11053	21	15454	Worm Pin for 11053	41
68910	Aluminum Closing Disc 80mm for 11053	2	15442	Screw 6x20 for 11053	22	Call for Options	Blade for 11053	42
15353	Screw 5x30 for 11053	3	AI213	O-Ring 3037 for 11053	23	Call for Options	Plate for 11053	43
15380	Back Motor Cover for 11053	4	15444	Brass Oil Cap for 11053	24	15455	Ring for 11053	44
15381	Bearing 6203 ZZ for 11053	5	15448	Seal for 11053 for 11053	25	15456	Pan Dim 300 x 220 for 11053	45
15414	Ring for 11053	6	15393	Gear for 11053	26	18658	Base for 11053	46
15415	Fan for 11053	7	15381	Bearing 6203 ZZ for 11053	27	70181	Washer 8x16x1.5 (4 pcs.) for 11053	47
AI211	Shaft with Rotor V.230 / 50 Hz. for 11053	8	15394	Seeger of 40 for 11053	28	15410	Screw 8x22 for 11053	48
20178	Stator for 11053	9	15389	Bearing 6203 2RS for 11053	29	17701	Switch for 11053	49
AI209	Long Banded Motor Housing for 11053	10	15387	Oil Seal 40x25x7 for 11053	30	19378	Bipolar Switch for 11053	49
AD423	Wheat 8x6 for 11053	11	46421	Key 4x4x12mm for Big Gear for 11053	31	AI214	Base Closing Bottom for 11053	50
AI212	Base Gasket for 11053	12	15395	Transmission Pin for 11053	32	15412	Screw 4 8x12 for 11053	51
15387	Oil Seal 40x25x7 for 11053	13	15450	Jacket Holder for 11053	33	79564	Rubber Feet with Screw for 11053	52
15447	Gear Pin for 11053	14	15401	Knob for 11053	34	19379	Capacitor UF20 for 11053	53
15389	Bearing 6203 2RS for 11053	15	15443	Screw 6x18 for 11053	35	15407	Grand PG11 for 11053	54
15392	Double Gear for 11053	16	42929	Hopper for 11053	36	15351	Screw 4x8 for 11053	55
15390	Propeller Gear for 11053	17	15400	Plunger for 11053	37	70168	Cable with Plug Mod.Schuko V.230 for 11053	56
15391	Key 3x3x15mm for 11053	18	15451	Cast Iron Jacket Holder (Grub Screw Included) for 11053	38			
15458	Ring 164 5x2 - Oil Seal for 11053	19	15452	Grub Screw for 11053	39			

PARTS BREAKDOWN

ITEM	MODEL
39714	MG-IT-0032-C

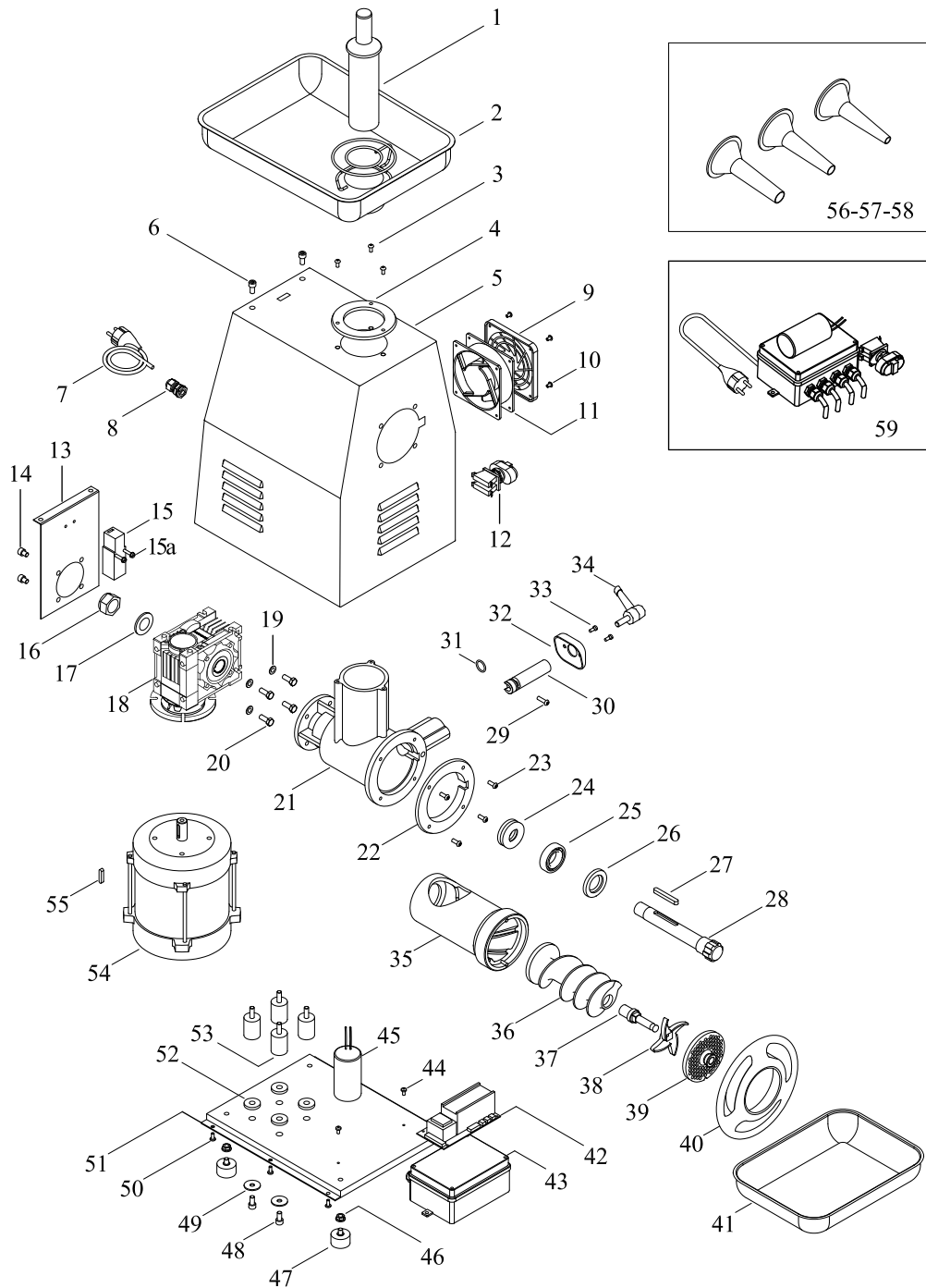

PARTS BREAKDOWN

ITEM	MODEL
39714	MG-IT-0032-C

Item No.	Description	Position	Item No.	Description	Position	Item No.	Description	Position
70162	Pestle for 39714	1	15363	Screw 8x20 for 39714	20	70202	Stainless Steel Wheel Round for 39714	40
70163	Hopper D76 Big Prot.Mano + Fork for 39714	2	70183	Internal Aluminum for 39714	21	15456	Pan Dim 300x220 for 39714	41
70164	Steel Screw 5x12 (3 pcs.) for 39714	3	70184	Flange Front Inox for 39714	22	70204	Circuit Board with Reversal for 39714	42
70165	Upper Flange Inox D76 for 39714	4	70185	Steel Screw 6x16 (4 pcs.) for 39714	23	70205	Electrical Box + PG for 39714	43
70166	Casing Steel for 39714	5	70186	Thrust Bearing 51305 for 39714	24	70206	Tapping Screw 4.6x10 (2 pcs.) for 39714	44
70167	Steel Screw 8x16 (2 pcs.) for 39714	6	70187	Bearing 6006 2RS for 39714	25	70207	Condenser 55 uF for 39714	45
70168	Cable with Plug Mod.Schuko V.230 for 39714	7	70188	Oil Seal 30x55x7 for 39714	26	70208	Self-Locking Nut M8 (4 pcs.) for 39714	46
15407	Gland PG11 for 39714	8	70189	Key 6x6x30 for 39714	27	70209	Foot Rubber Thread (4 pcs.) for 39714	47
70170	Filter only Three Phase for 39714	9	70190	Pin Driver Helix for 39714	28	70210	Screw M6x20 (4 pcs.) for 39714	48
70171	4x45 Screw for Fan (4 pcs.) for 39714	10	70191	Wheat Inox 6x20 for 39714	29	70211	Washer 6x18x1.5 (4 pcs.) for 39714	49
70172	Fan 230V only Single Phase for 39714	11	70192	Mouth Stopping Pin for 39714	30	70212	Screw 5x12 (6 pcs.) for 39714	50
70173	Switch Triple 24V. Reverse for 39714	12	70193	Ring 3075 for 39714	31	70213	Fund Closure for 39714	51
70174	Bracket Door Micro for 39714	13	70194	Stud Stainless Steel Lever for 39714	32	70214	Rubber Anti for 39714	52
70175	Screw 8x12 (4 pcs.) for 39714	14	70195	Steel Screw 5x12 (2 pcs.) for 39714	33	70215	Vibration Motor for 39714	53
70176	Micro Switch for 39714	15	70196	Lever Stop for Mouth Reels for 39714	34	70216	Complete Motor V.230 / 60Hz Hp.3 for 39714	54
70177	Screw + Nut for Micro 5x35 (2 pcs.) for 39714	15a	70197	Mouth Meat Inox for 39714	35	70189	Key 6x6x30 for 39714	55
70178	Self-Locking Nut M24x1.5 for 39714	16	70198	Stainless Steel Worm and Pin for 39714	36	70218	Funnel Mod.32 Hole 15 for 39714	56
70179	Washer 25x40x2 for 39714	17	70199	Pin Knifeholder for 39714	37	70219	Funnel Mod.32 Hole 20 for 39714	57
70180	Gear for 39714	18	Call for Options	Blade for 39714	38	70220	Funnel Mod.32 Hole 25 for 39714	58
70181	Washer 8x16x1.5 (4 pcs.) for 39714	19	Call for Options	Plate for 39714	39	70221	Kit Electrical V.230 / 50-60Hz for 39714	59

ELECTRICAL SCHEMATICS

ITEM	MODEL
11051	MG-IT-0012-C

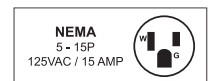
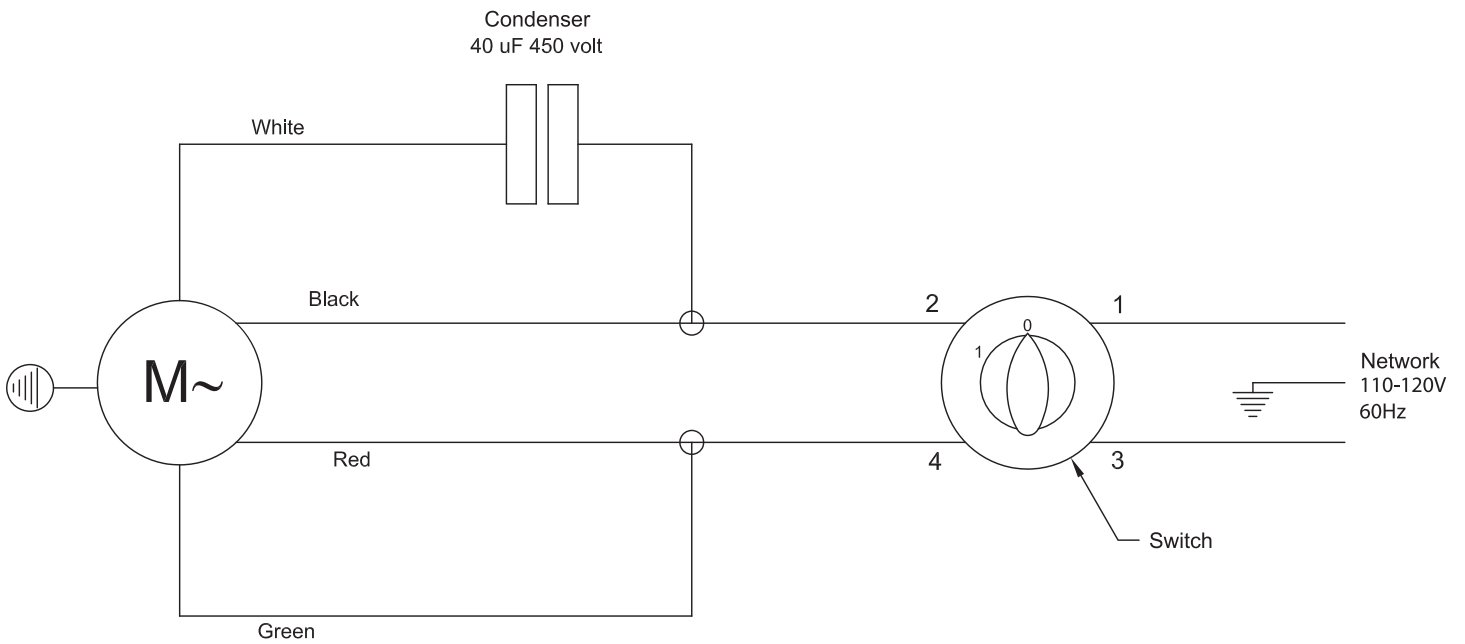

PARTS BREAKDOWN

ITEM	MODEL
11053	MG-IT-0022-C

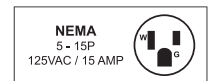
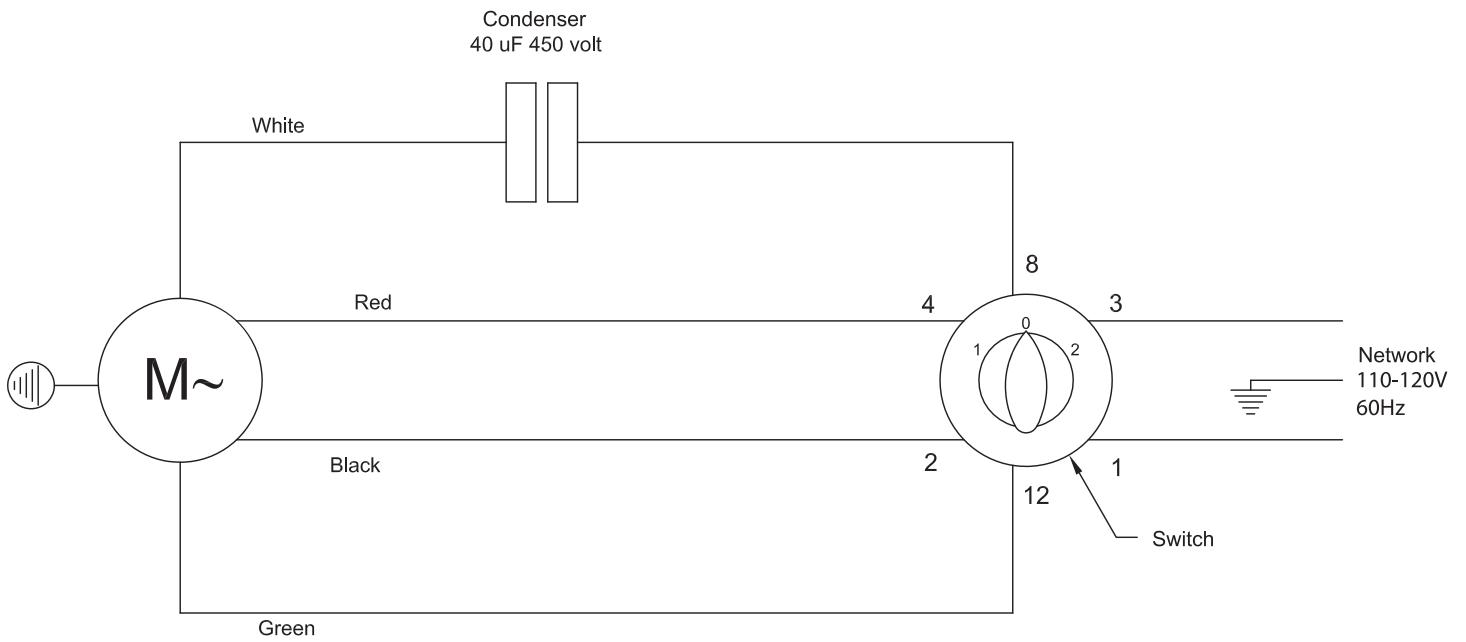

PARTS BREAKDOWN

ITEM	MODEL
39714	MG-IT-0032-C

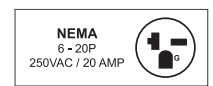
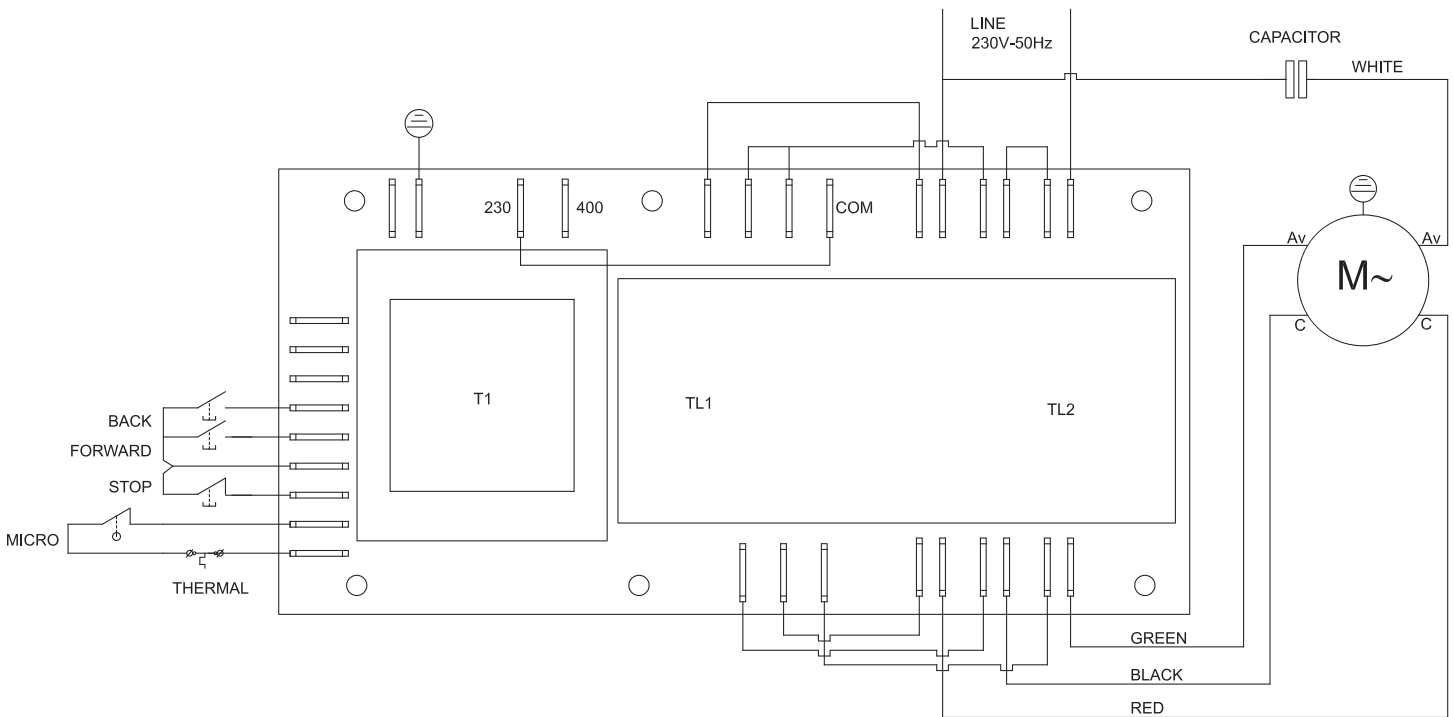

NOTES

WARRANTY REGISTRATION

Thank you for purchasing an Trento product. To register your warranty for this product, complete the information below, tear off the card at the perforation and then send to the address specified below. You can also register online by visiting:

Merci d'avoir acheté un produit Trento. Pour enregistrer votre garantie pour ce produit, complétez les informations ci-dessous, détachez la carte au niveau de la perforation, puis l'envoyer à l'adresse spécifiée ci-dessous. Vous pouvez également vous inscrire en ligne en visitant:

Gracias por comprar un producto Trento usted. Para registrar su garantía para este producto, complete la información a continuación, cortar la tarjeta en la perforación y luego enviarlo a la dirección indicada a continuación. También puede registrarse en línea en:

<https://omcan.com/warranty-registration/>

For mailing in Canada

Pour postale au Canada

Por correo en Canadá

For mailing in the US

Pour diffusion aux États-Unis

Por correo en los EE.UU.

TRENTO

PRODUCT WARRANTY REGISTRATION

3115 Pepper Mill Court,
Mississauga, Ontario
Canada, L5L 4X5

TRENTO

PRODUCT WARRANTY REGISTRATION

4450 Witmer Industrial Estates, Unit 4,
Niagara Falls, New York
USA, 14305

or email to: trentoservice@trentoequipment.com



Purchaser's Information

Name: _____

Address: _____

City: _____ Province or State: _____ Postal or Zip: _____

Country: _____

Dealer from which Purchased: _____

Dealer City: _____ Dealer Province or State: _____

Invoice: _____

Company Name: _____

Telephone: _____

Email Address: _____

Type of Company:

Restaurant Bakery Deli

Butcher Supermarket Caterer

Institution (*specify*): _____

Other (*specify*): _____

Model Name: _____ Model Number: _____

Serial Number: _____

Machine Description: _____

Date of Purchase (MM/DD/YYYY): _____

Date of Installation (MM/DD/YYYY): _____

Would you like to extend the warranty? Yes No

Thank you for choosing Trento | Merci d'avoir choisi Trento | Gracias por elegir Trento

TRENTO

ELEVATING CULINARY EXCELLENCE

TRENTO IS A SIGNATURE LINE OF PROFESSIONAL
RESTAURANT EQUIPMENT FROM OMCAN
OFFERING PREMIUM EUROPEAN BRANDS TO THE
NORTH AMERICAN MARKET.

Thank you for your purchase!



Follow us on social media
@trentoequipment

